



SKIOLD DAMAS HOTYP



SKIOLD MAKES THE DIFFERENCE!



SKIOLD DAMAS Hotyp

Function

The material to be treated (1) runs along the bottom of the indented cylinder cover (2). Through the rotation of the indented cylinder cover the short material is lifted up into the trough (4) and is carried to the trough outlet (M) by means of a worm (5). The long material falls out of the indents (6) before it reaches the trough (4) and continues towards the cover outlet (K). The inclination of the trough (4) can be adjusted during operation and is shown on a graduated scale.

When the indented cylinder is operating as short seed indented cylinder (R) it is equipped with a stirrer (3), ensuring that each seed comes into contact with the indents. As long seed indented cylinder (L) a special distribution arrangement (8) is incorporated, giving max. utilization of the cover.

Suction pipe branches (7) and doors for samples are standard equipment. The bottom frame of the indented cylinder can be delivered with legs in 5 different standard heights.

Modular system

With the DAMAS modular system the most flexible indented cylinder arrangement in any combination can be built, see the standard combinations A1-C5. Without any difficulties it is possible to change or extend the indented cylinder battery. The outlet module is provided with a double two-way distributor, permitting to change the function of the indented cylinder.

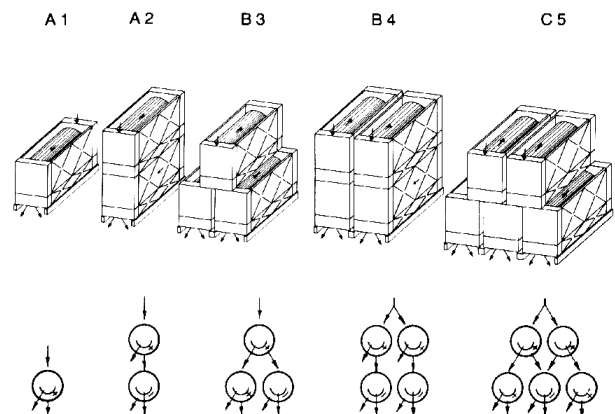
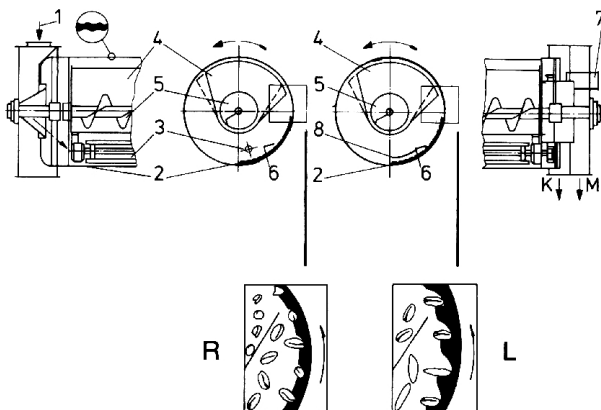

TECHNICAL SPECIFICATIONS	520	730	930	940
Guiding capacity, barley and wheat, A1 and A2 (t/h):	4	8	12	15
Guiding capacity, barley and wheat, B3 (t/h):	-	12	18	20
Guiding capacity, barley and wheat, B4 (t/h):	-	16	24	30
Guiding capacity, barley and wheat, C5 (t/h):	-	24	-	-
Cover diameter (mm):	500	700	930	930
Cover length (mm):	1980	2910	2910	3910
Motor (kW):	1.5	2.2	2.2	3.0
Weight, A1 (incl. cover) (kg):	500	1050	1600	2000
Weight, A2 (incl. covers) (kg):	900	1950	3000	3800
Weight, B3 (incl. covers) (kg):	-	2900	4500	5700
Weight, B4 (incl. covers) (kg):	-	3800	6000	7200
Weight, C5 (incl. covers) (kg):	-	4800	-	-